

Flux Power L48-G1 Installation Guide

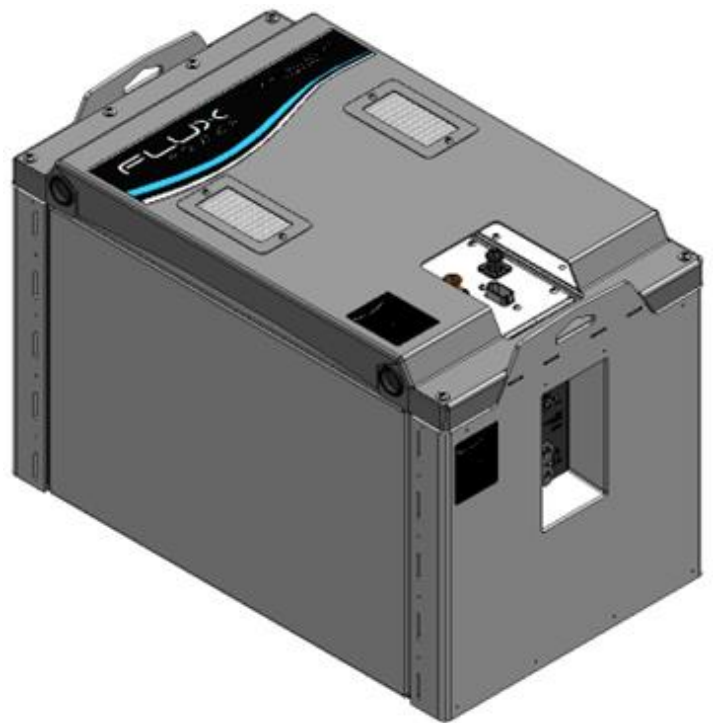

Installation

1 Deliverables

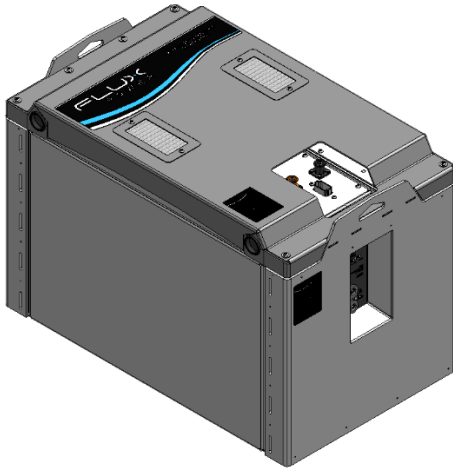

Battery
QTY: 1

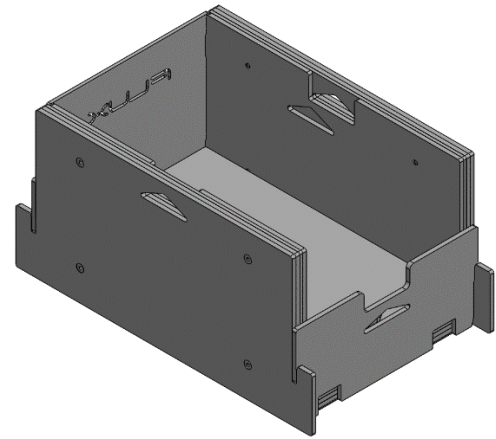

Weight Adapter
Qty: 1

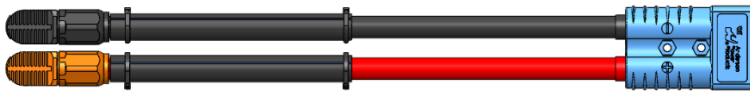

Power Cables (varying connector and length)
QTY: 1

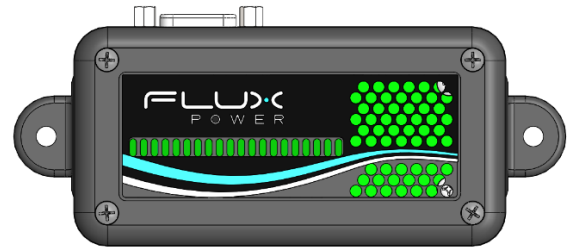

External SOC Gauge
QTY: 1

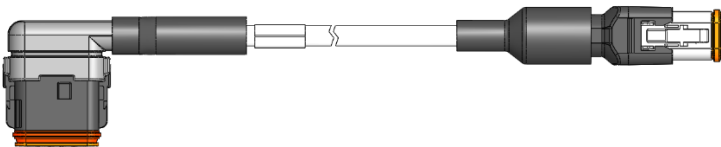

External Harness (varying connections and length)
QTY: 1

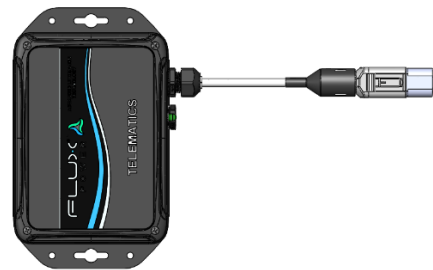

Telematics Box (if applicable)
QTY: 1

2 Battery Installation

2.1 Installing Battery into Weight Adapter

2.1.1 Lifting Points

Use the two lifting points of the battery to lift the battery up. A set of hooks with proper chains or lifting straps is recommended.

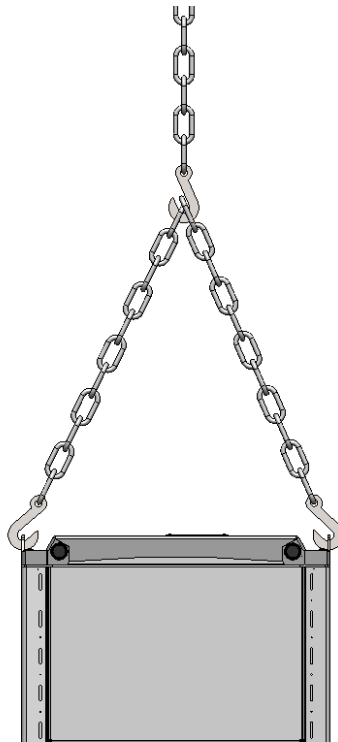
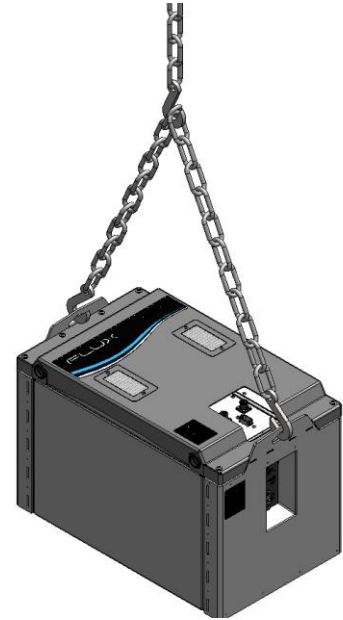
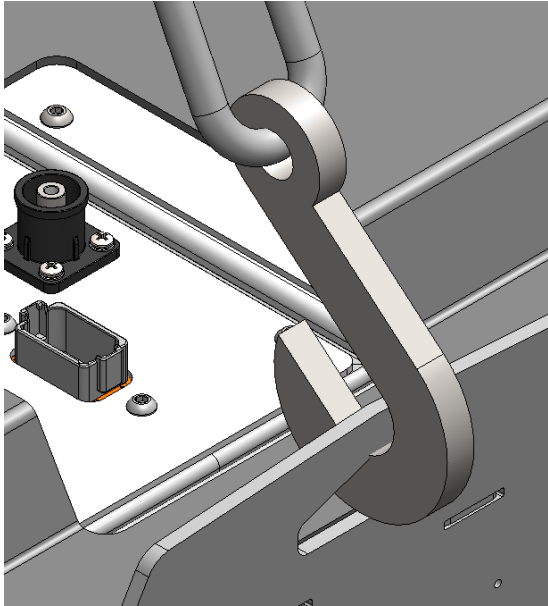

Installation

2.1.2 Orientation

The battery should be oriented such that the front of the battery faces the same direction as the open side of the weight adapter. The I.D. plate of the battery faces this direction as well.

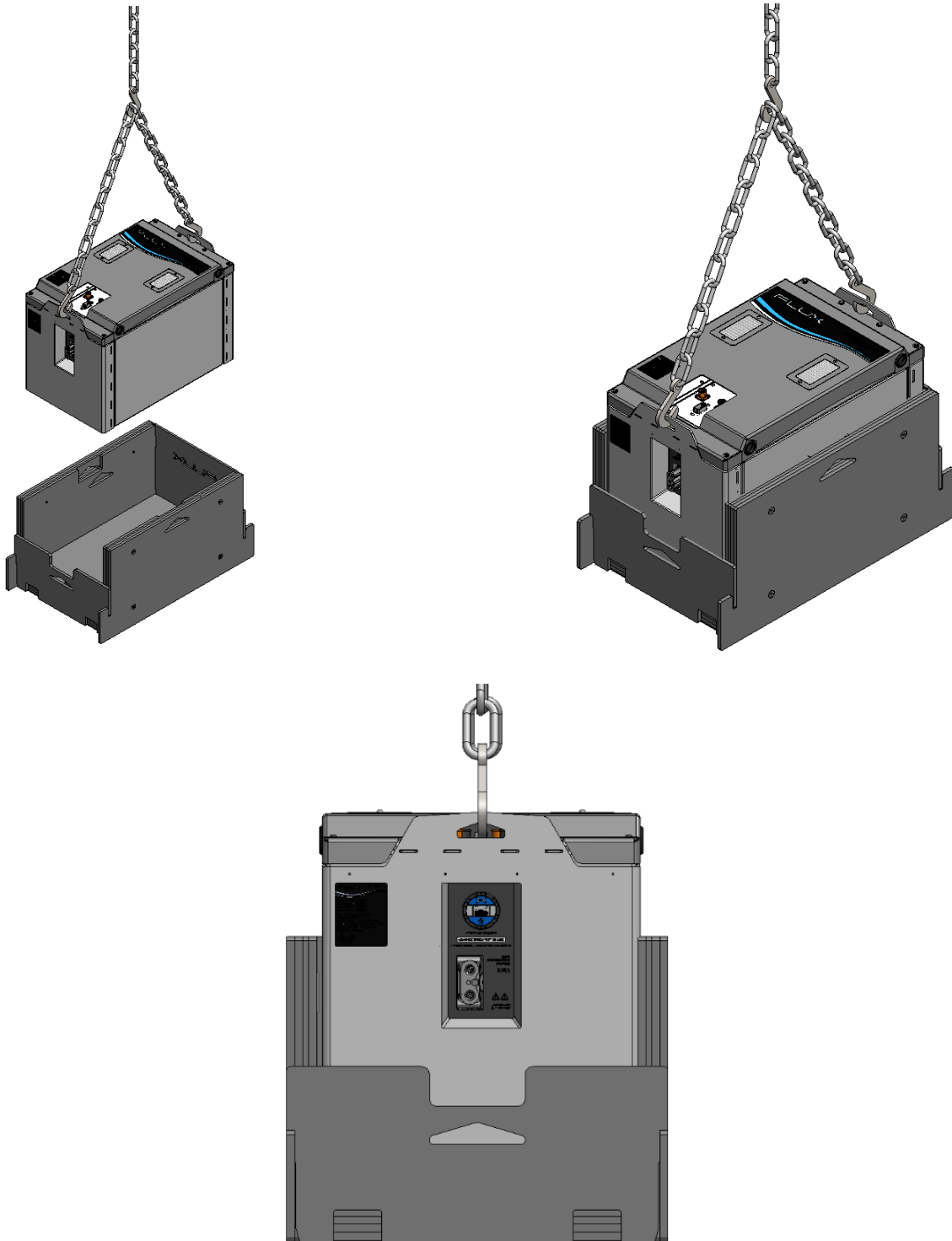

Installation

2.2 Installing Battery and Weight Adapter into Truck

2.2.1 Lifting Points

Use the two lifting points on the side of the weight adapter to lift the unit. A set of hooks with proper chains or lifting straps is recommended.

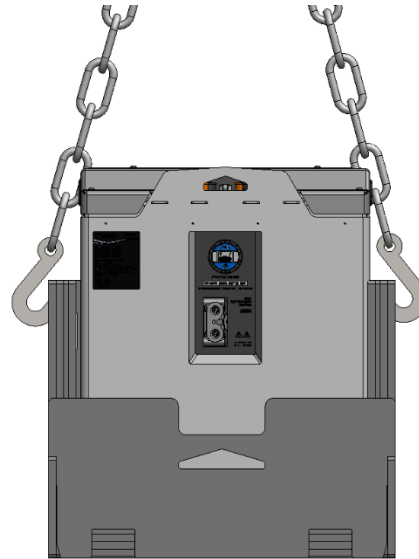
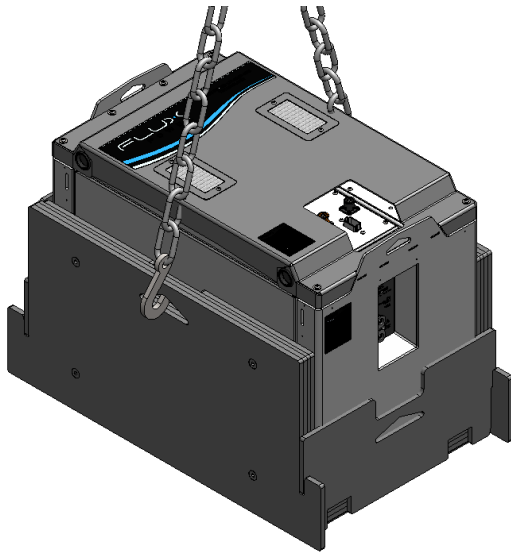

2.2.2 Drop-in

Lift and align the battery into the truck's battery compartment by positioning the chain or straps through the gap of the truck's overhead guard. Tighten the truck gate and bumper if the battery compartment has adjustable stoppers present.

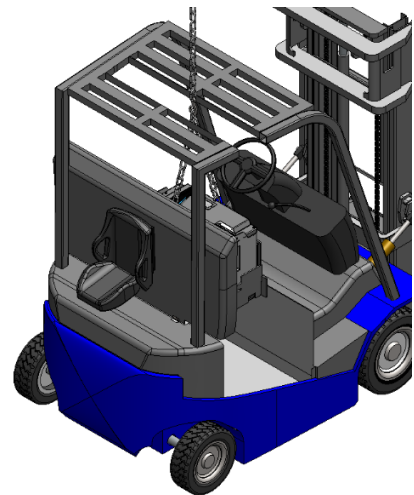
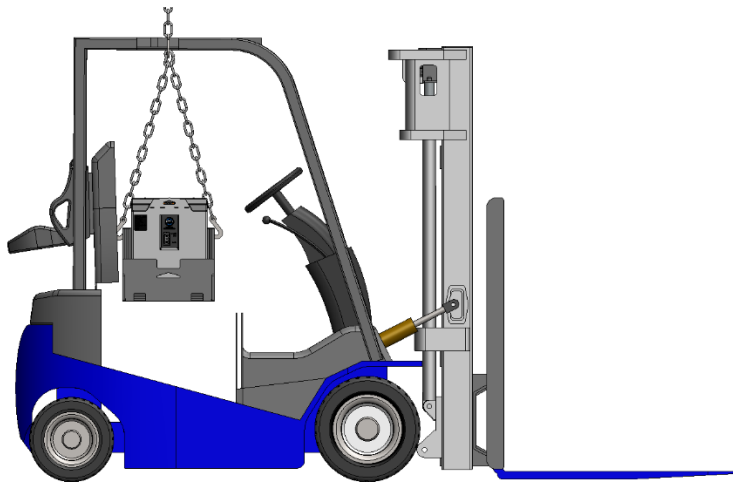

Installation

2.2.3 Slide-in

Sliding the battery into the compartment requires that both the battery and weight adapter be suspended in the air and then pushed into the compartment. The truck's battery compartment will have a sliding tray for the battery to slide in and out of the compartment. This may require one truck to suspend the loaded sliding tray in the air, and a second truck to push the loaded sliding tray back into the compartment. Pull the sliding tray out to place the unit on and then push the tray back into the compartment. Remove the lifting equipment prior to sliding the battery into the compartment.

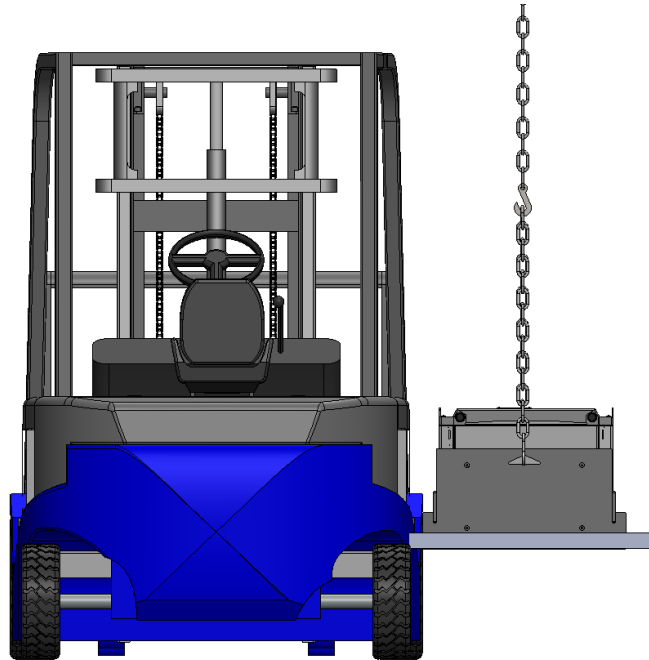

2.3 Installing Power Cables

2.3.1 Power Connections

Power connections can only be inserted into the same color and key receptacles. An orange insert will slide into an orange receptacle, and a black insert into a black receptacle. Align the keys of the insert to that of the receptacle to properly insert the connection. A connector can also be removed by pressing the button on the side of the plug and pulling the connector straight out.

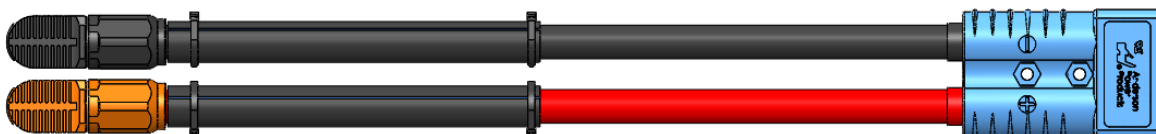
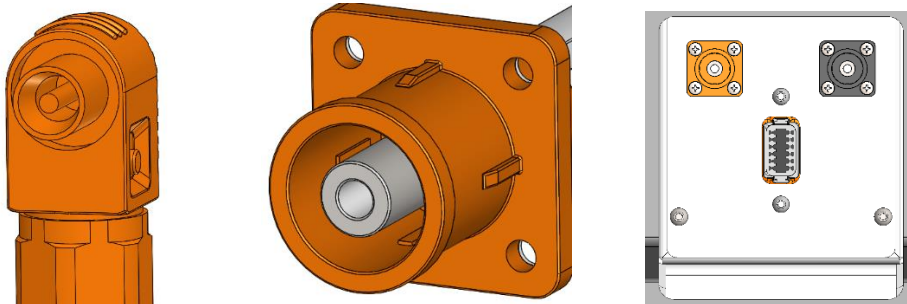

3 External Accessories Installation

3.1 External SOC Gauge

3.1.1 Mounting Points

The external SOC gauge has two mounting points to mount onto the truck frame. These two mounting points can be mounted onto the truck with self-tap screws or zip ties.

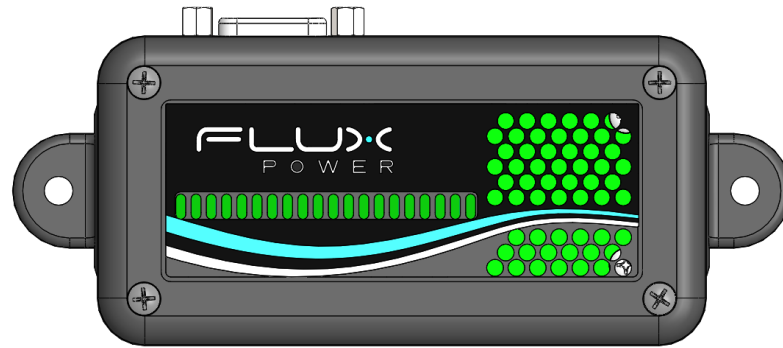

3.1.2 Mounting Location

Mount the external SOC gauge so that the Flux Power logo and the LEDs face the operator. Mount the SOC gauge on a secured spot where collisions with other objects cannot damage it.

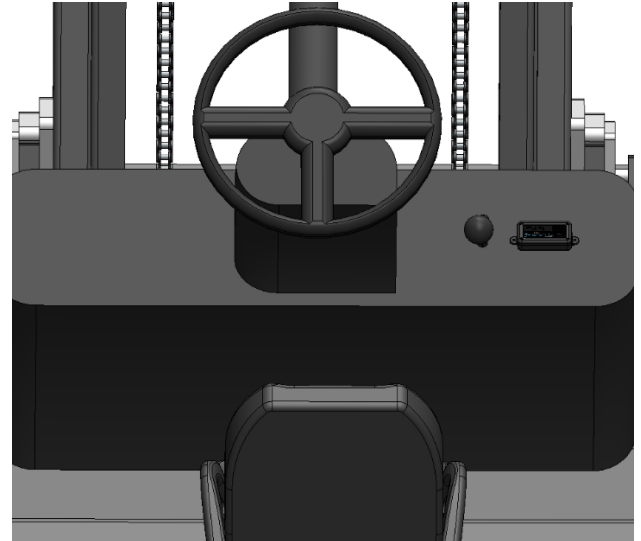
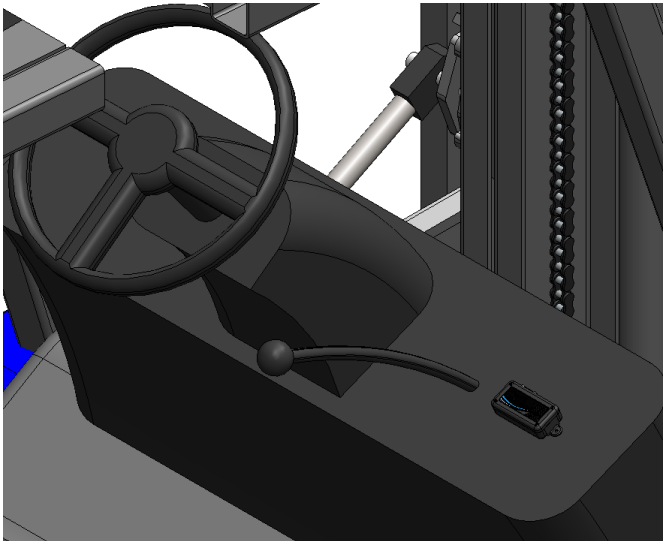

Installation

3.2 Telematics

3.2.1 Mounting Points

Use the 4 holes on the side to mount the telematics box onto the truck by tapping into the truck frame; or use the 2 slots on the side to zip-tie the telematics box onto the truck frame.



3.2.2 Mounting Location

Mount the telematics box underneath the overhead guard. Do not mount the telematics box underneath the driver's seat. If there is no overhead guard present, then mount the telematics box on a secured spot where collisions with other objects cannot damage it.

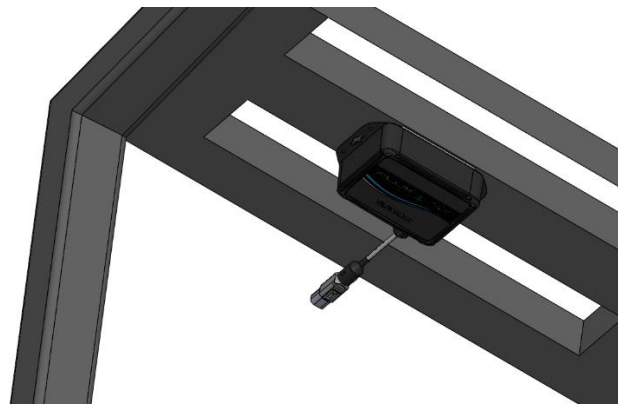

3.3 External Harness

3.3.1 Mounting Points

Use zip ties to mount the external harness's body along the truck frame. Different external harnesses have different connectors depending on the truck and the customer's order.

3.3.2 Mounting Location

Wrap the external harness within the inside of the truck frame to limit damage to the harness from the truck's surroundings. Recommended locations are highlighted striped green. Areas to avoid are highlighted checkered red.

Recommended locations in striped green:

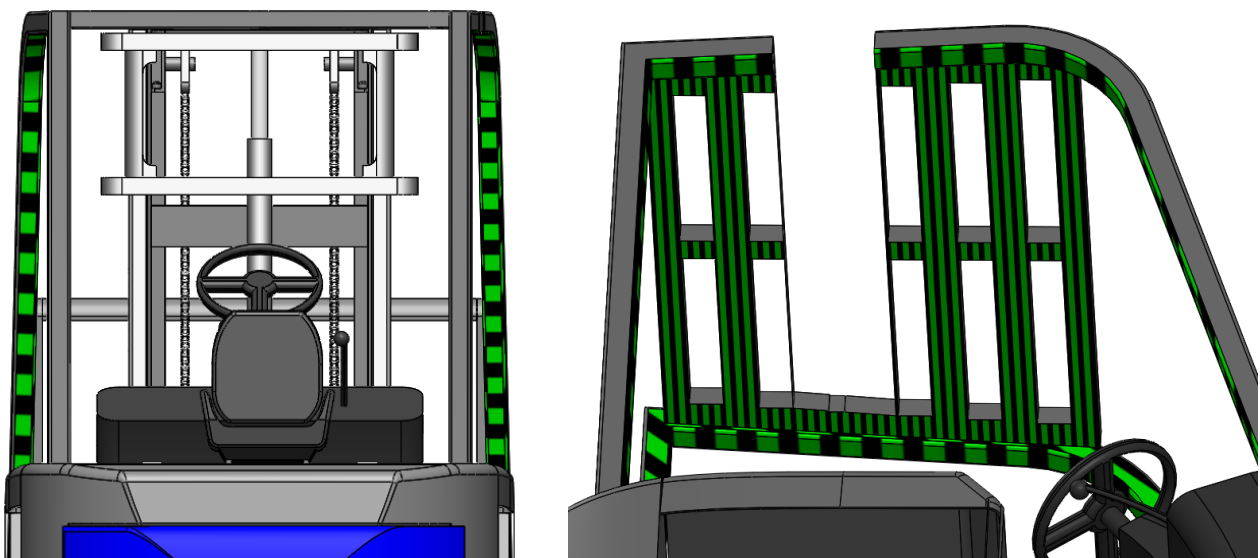
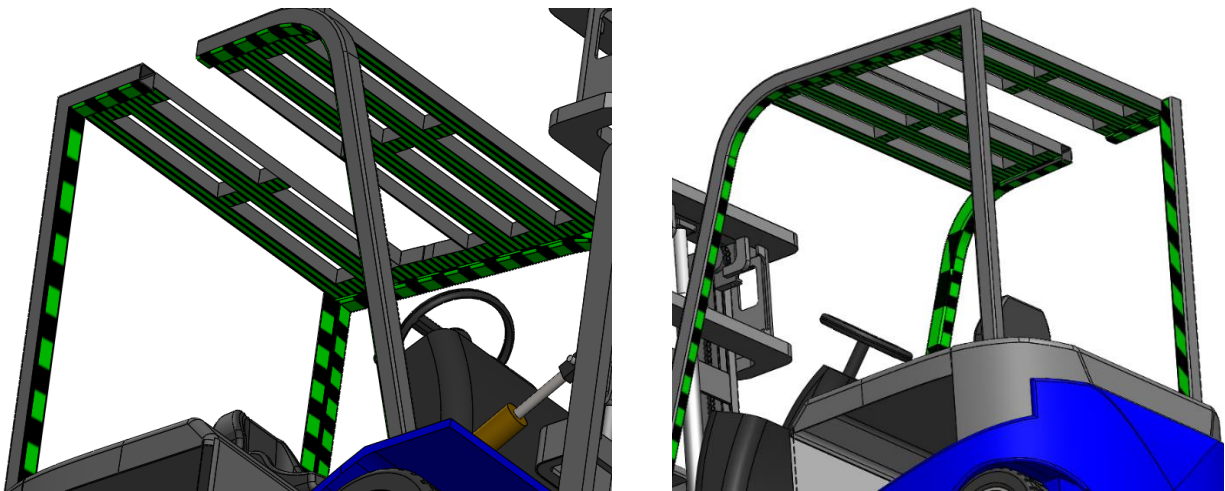

Installation

Avoid mounting the harness in areas where it can be pinched or scraped. Areas to avoid in checkered red:

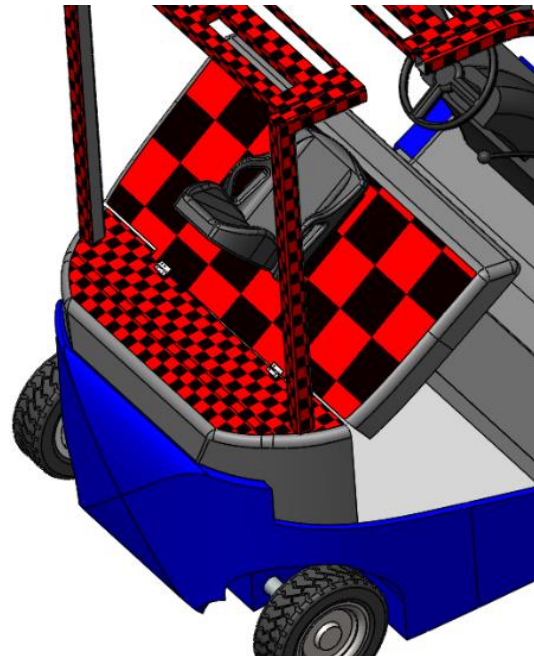
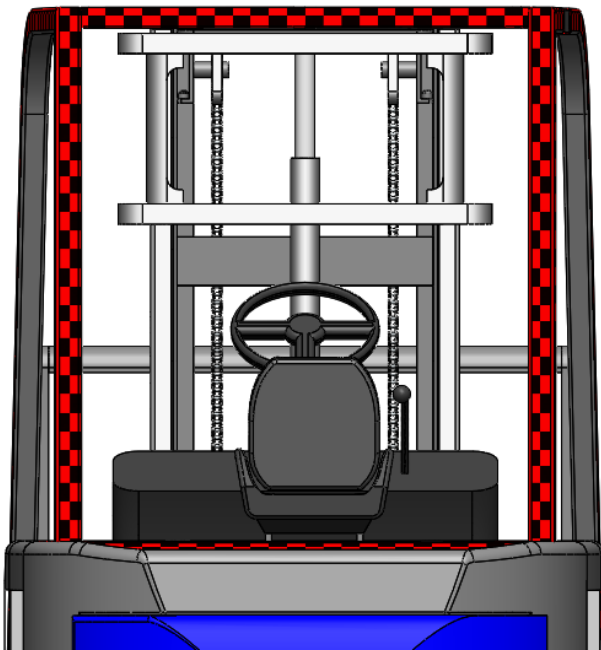
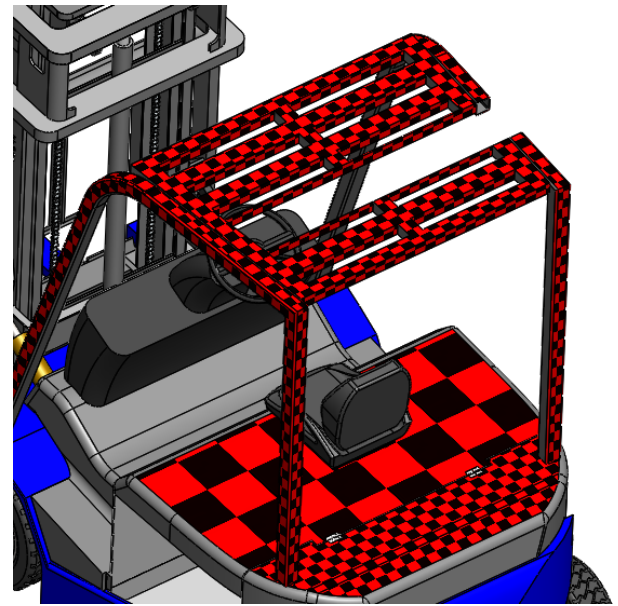
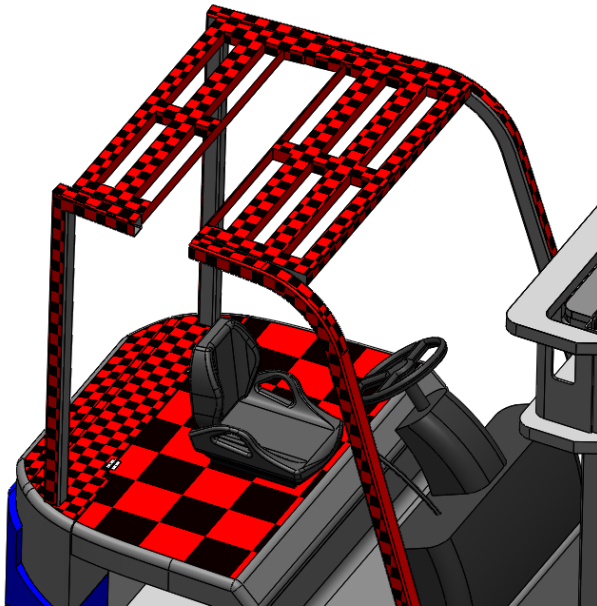

4 Operation

4.1 Discharging the Battery

The battery will need to have an external harness and all connectors properly connected to any external accessories present to discharge. External harness connections will vary between different harnesses and truck configurations. An external harness will connect to the battery's 12-pin communications port. The battery's power cables will have a complimentary connector to the truck. The power cables are always connected to the truck. Do not charge through the power cables.

An external harness connection to the 12-pin communications port's connection:

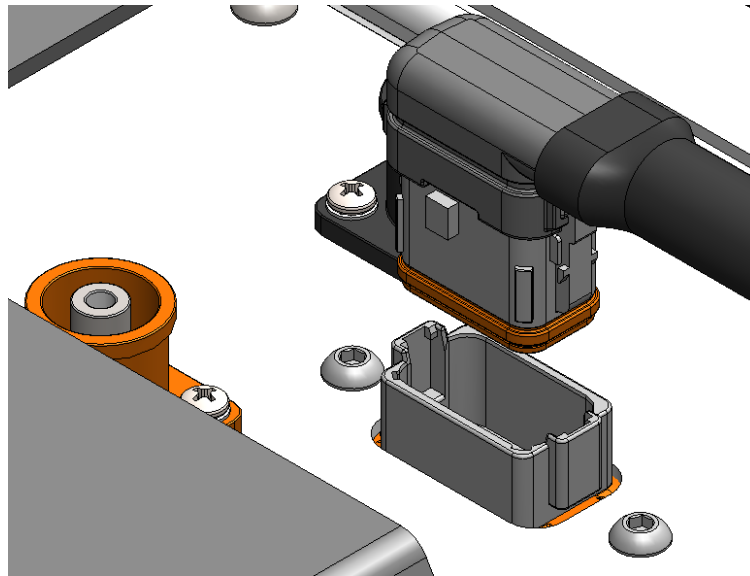

Telematics harness connection is a 4-pin connection:

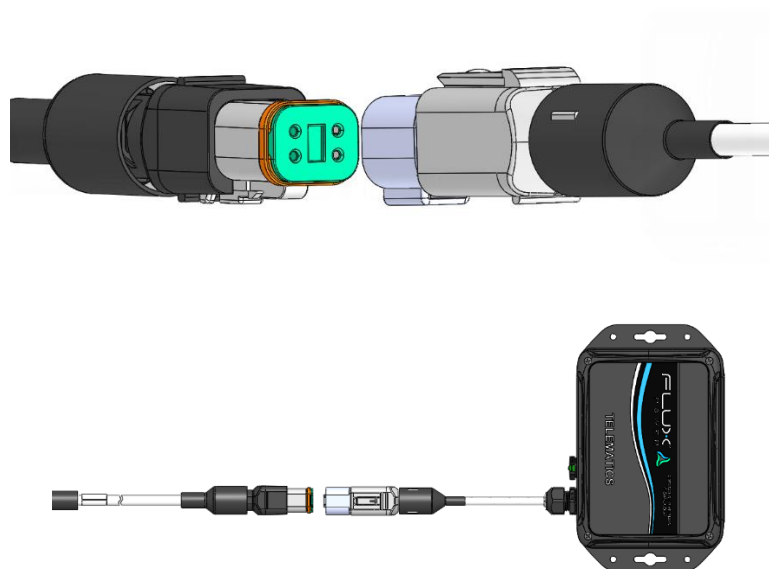

Installation

External SOC gauge connection is a 9-pin connection. Turn the set screws on the connector to properly secure this connection:

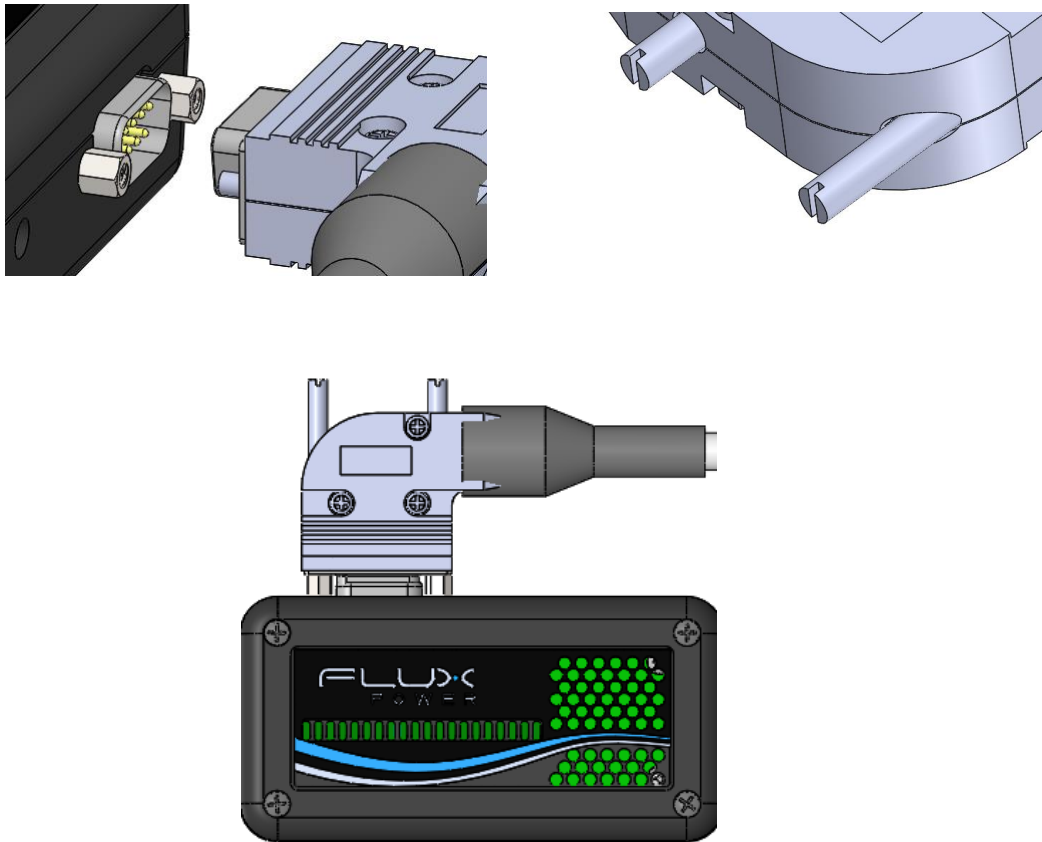

This battery is equipped with an internal BDI. When the external harness is connected correctly, the battery is turned ON by pressing and holding the power button symbol on the BDI for at least 3 seconds. The battery is turned OFF by pressing and holding the power button symbol for at least 3 seconds.

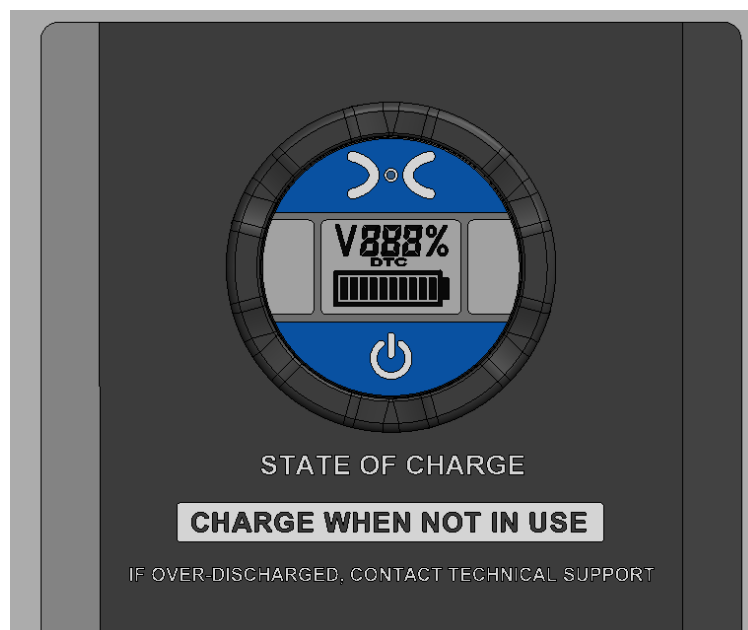

4.2 Charging the Battery

The battery's charge port will have a complimentary connector to the external charger. The connector will be an A320 connector, but some battery configurations may vary. The battery will cut power to the truck after 10 seconds of detecting a proper connection to the charger. Within those 10 seconds, the external SOC gauge of the battery will alarm. If the charger's connector is not fully inserted into the charge port, then the battery will not charge.



5 Flux Power Contact Details

Flux Power Inc.
Address: 2685 South Melrose Drive,
Vista, CA 92081
Tel: 877-505-3589
Fax: 760-741-3535
Email: Support@fluxpower.com
Web: www.fluxpower.com

WARNING – Risk of Fire – No User Serviceable Part

Copyright © 2018 Flux Power, Inc. All rights reserved. Flux Power, the Flux Power Logo and Flux Power LiFT Pack are registered trademarks or trademarks of Flux Power, Inc. All other brands and product names are trademarks or registered trademarks of their respective owners. This information is intended for the use of Flux Power customers only. Any other use without the express written consent of Flux Power, Inc. is strictly prohibited